



PREMIUM ELECTRIC FIRES 2025



SHOWROOM EXCLUSIVE





## WELCOME TO CELSI



At Celsi we know how important it is to create a stylish and relaxing living environment. That's why we've developed this collection of premium electric fires.

This brochure has been designed to make the purchase of your new Celsi fire as simple as possible. I hope you find it both informative and inspiring.



## SHOWROOM EXCLUSIVE

Electriflame DLX products provide all the warmth, comfort, and style to be expected from high-performance electric fires. Our showroom network of independent retailers is exclusively selected to display our products. These highly experienced retailers can demonstrate all the features and benefits of owning a DLX fire. A retailer can provide guidance for your individual requirements, and assist you with choosing and installing the most appropriate model for your home.

We want you to experience the very best product performance, customer care, and service satisfaction that we believe you will find from our CELSI DLX retailers.



## PEACE OF MIND ASSURANCE

We believe our success stems from a combination of innovative design, investment in technology and the highest quality manufacturing standards. To reflect our belief in their quality and durability, Celsi DLX fires carry a 5 year warranty, subject to terms and conditions.



Through design innovation and precision engineering Celsi have captured every natural element and characteristic that embodies fire. This has been stunningly reproduced and encased behind safe-to-touch sleek glass walls.

## CONTENTS

SMART FUNCTIONALITY	6-7
ADVANCED FEATURES	8-9
ART OF TRANSFORMATION	10-11
NATURAL OAK & WOODLAND CERAMIC LOGS	12-13
3-SIDED FIRES	14-23
WALL INSET FIRES	24-35
HEARTH INSET FIRES	36-37
MEDIA WALL SUITES	38-39
PREMIER BOARD SUITES	40-47
LIMESTONE SUITES	48-57
DIMENSIONS	58-64



## SMART FUNCTIONALITY

### EFFORTLESS WARMTH, CAPTIVATING STYLE.

Experience the next generation of electric fires with the Electriflame DLX. Enjoy the ambiance of a vibrant, realistic flame, enhanced by our immersive Animation mode. Watch as the soft glow seamlessly transitions through a spectrum of colors, creating a relaxing atmosphere at the touch of a button. Control your comfort with ease, from the warmth of the fire to the captivating play of light.

The Electriflame DLX: Where style meets simplicity.

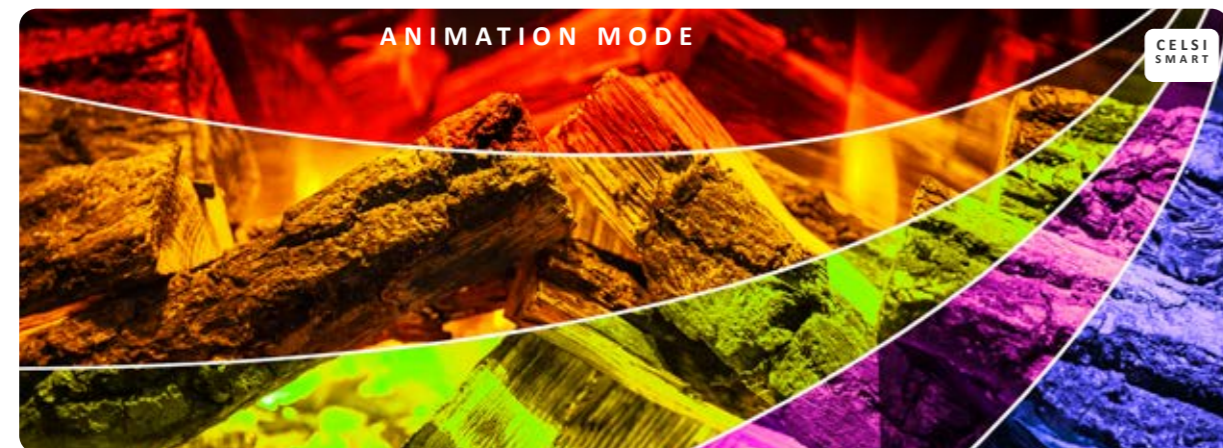

ELECTRIFLAME® DLX COLOUR CONTROL.



### COLOUR

Enjoy 16 pre-set ambient colour modes and over 100 multi-colour combinations to customize the flames, logs, and embers. LED lights above, beneath, and behind the fuel bed create the illusion of hot embers, burning logs, and tall flames for a real fire experience.



Operated via Celsi Smart handset and Celsi Smart App.

### CONNECTIVITY

Get connected with our feature-rich and simple to operate CELSI Smart App. Available to download on the App Store, or get in on Google Play!

### CONTROL

Control your fire from your smart phone or tablet with full handset functionality.



Further applied smart technology allows you to voice activate your fire using Amazon Alexa and Google Assistant.



Scan the QR code to download our App.



Celsi Smart app control

## ADVANCED FEATURES

Experience the warmth and ambiance of a DLX fire all year round, effortlessly operated to suit even the busiest lifestyles. When it's time for comfort and relaxation our premium heating system quietly emits warm air, letting you enjoy beautiful flames in peace with minimal operational noise.

One of many advanced features in our DLX fires is ISOFLAME, which allows independent flame operation when no heat is required. Celsi integrates the finest industry-designed features, ensuring optimal energy-saving performance and assurance. Please take a moment to explore our Advanced Features section.



Minimal operational noise. Quiet warmth, complete control.

## Optimal energy saving performance and assurance.

Our fires are built with high quality low energy consumption LEDs that provide incredible flame brightness and colour saturation, whilst maintaining sensible and economical energy use.



### THERMOSTATIC HEATING

Pre-set your heat comfort level for automatic temperature control via the handset.



### TIMER FUNCTION

Programmable 7-day heating timer with hourly on/off control.



### LED EFFICIENCY

Advanced lighting is used throughout our product. Our onboard LED's ensure effective energy saving low power consumption.



### ISOFLAME

Independent flame effect capable of displaying in isolation when no heat is required from the appliance.



### COLOUR SMART

16 colour vibrant presets with 100+ options to customise the light ambience on flames, logs, and ember bed.



### FLAME SPEED

Controlable flame speed. Customize the intensity and movement of the flames to perfectly match your desired mood and setting.



Celsi Smart handset.



Compliance with Electrical Energy Rated Product (ERP)



Conformity assessed and certified UK & EU



## ART OF TRANSFORMATION

### 3-SIDED GLASS

DLX large format built-in fires have the power to transform a room, crafted to complement any home, regardless of size. Whether you're adding one of our on-trend media wall units or renovating an existing chimney breast, we offer five product sizes, with our largest model measuring an impressive 2 meters.

### CONFIGURATION

Desirable results can be achieved with the number of installation possibilities available. Our fires are supplied with side blanking panels giving you the option to customise your installation by choosing a full aspect 3-sided glass fire, a 2-sided left or right configuration, or to simply install as a single glass fronted wall inset fire.

For more advice and to explore installation options tailored to your home, visit a Celsi DLX showroom. Our knowledgeable retailers will provide expert guidance and demonstrate the full range of our products, helping you make the perfect choice.



3-sided glass installation.



2-sided glass installation.



1-sided glass installation.

### MOOD LIGHTING

Enhance your feature wall transformation by adding LED lighting via the USB port on your DLX fire. This option is perfect for creating ambient mood lighting and adds a stylish design element to the entertainment center of your home.

For comprehensive advice on integrating ambient mood lighting with your DLX fire, visit your nearest Celsi retailer. They can offer expert guidance tailored to your specific design and installation preferences.



USB port available on large format fires.

### FIRE TO TV SIZE

Finding the right balance between fire and TV size is key when designing a Media wall. As televisions have grown larger, so have our fireplaces. Large TVs are often mounted or inset above the fireplace, raising the question: what sizes work best together?

To help, we offer a 'recommended size guide' based on a 16:9 aspect ratio, that takes the diagonal TV measurement into account. This guide ensures the fireplace is slightly wider than the TV, creating a balanced and visually pleasing result for your space. It's always best to measure the space of the overall room size and consider your personal preferences before making a final decision.

Fire size	TV Diagonal	TV Width
Millimetres	Inches	Millimetres
DLX 1000	(48)	1073
DLX 1250	(55)	1228
DLX 1600	(65)	1449
DLX 1800	(75)	1676
DLX 2000	(85)	1893



## NATURAL OAK LOGS

DLX fires combine sensational flame effects with genuine oak logs, each split to reveal the unique character of the oak. Chosen for its deep rich color and distinctive textured bark, hardwood oak provides a beautiful natural finish for these premium electric fires.

### RESIN BONDED LOGS

Our pre-assembled resin-bonded fuelbed is meticulously handcrafted by skilled artisans. They split and sculpt high-quality oak, selectively flame-charring the logs and chippings to develop wood-burning character. These made-to-measure log-sets offer a simple and efficient installation solution.

### CUSTOM LOOSE LOGS

Alternatively, you may choose our loose oak logs arrangement, each log carefully wrapped and individually referenced with an easy-to-follow layout plan before leaving our UK factory.

Whether you choose a fixed fuelbed, or loose layout, our genuine oak logs deliver an authentic fire experience, looking stunning when powered on, and naturally pleasing when off.



ELECTRIFLAME® DLX

100% – Natural Authentic Oak



Natural oak is available for all DLX models. \*Custom loose logs come complete with a simple to follow layout guide, fully supported with instructional demonstration videos.



Retaining character



Attention to detail

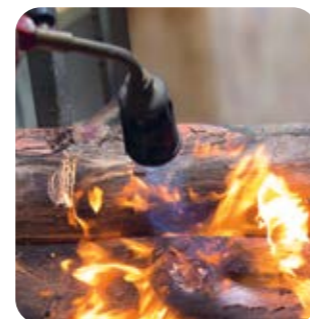

Log charring aesthetics

Patented technologies bring new dimensions to the electric fire market as fuel bed and flames merge together in a living fire effect that blurs the line between reality and illusion. Cutting-edge technology replicates the natural flicker, color, and movement of real flames. This creates an authentic fire experience, the effects are astonishing, and are at the forefront of our premium electric fires.

## WOODLAND CERAMIC LOGS



Blurring the lines between reality and illusion with naturally detailed woodland ceramic logs. \*Ceramic logs come complete with a simple to follow layout guide, fully supported with instructional demonstration videos on large format fires.



Natural bark chippings with all large format fires.

## PATENTED TECHNOLOGIES

Multi Flame Projection®

Living Ember Bed®

DLX

DEFINED BY EXCELLENCE



Electrifiame Built-In 3 Sided Smart Fire

**Features**

- Glass Fronted Fire
- Multi Flame Projection Technology®
- Living Ember Bed Technology®
- Flame Speed Control
- Natural Oak Logs & Woodland Ceramic Logs
- Bark chippings
- 16 pre-set colours/100+ custom/Animation mode
- LED brightness control
- Thermostatic remote & manual control operation
- CELSI App controllable. iOS & Android
- Amazon Alexa and Google Assistant compatible
- Side blanking for 2 & 1 sided installations



Celsi Smart Fires have 16 pre-set ambient colour modes, and over 100+ multi colour combinations to customise the light ambience on flames, logs, and ember bed. To simplify your choice relax and enjoy a slow cycle through the colour spectrum in our fully immersive Animation mode.



**CELSI SMART APP**

Feature-rich and simple to operate. Control your fire from your smart phone or tablet with full handset functionality.



3-sided glass installation. Natural Oak Logs. Ceramic Logs page 13, or scan the QR code below.

**Specification**

Visual Dimensions: mm	H 397 x W 2002 x D 220
Heat Output	1.0kW – 2.0kW
Model Number	Custom Oak Logs EDXB20RE Resin Bonded Oak Logs EDXR20RE Ceramic Logs EDXL20RE



NATURAL OAK LOGS



CERAMIC LOGS





## DLX 1800

### Electriflame Built-In 3 Sided Smart Fire

#### Features

- Glass Fronted Fire
- Multi Flame Projection Technology®
- Living Ember Bed Technology®
- Flame Speed Control
- Natural Oak Logs & Woodland Ceramic Logs
- Bark chippings
- 16 pre-set colours/100+ custom/Animation mode
- LED brightness control
- Thermostatic remote & manual control operation
- CELSI App controllable. iOS & Android
- Amazon Alexa and Google Assistant compatible
- Side blanking for 2 & 1 sided installations



Celsi Smart Fires have 16 pre-set ambient colour modes, and over 100+ multi colour combinations to customise the light ambience on flames, logs, and ember bed. To simplify your choice relax and enjoy a slow cycle through the colour spectrum in our fully immersive Animation mode.



#### CELSI SMART APP

Feature-rich and simple to operate. Control your fire from your smart phone or tablet with full handset functionality.



1-sided glass installation. Natural Oak Logs. Ceramic Logs page 13, or scan the QR code below.



NATURAL  
OAK LOGS



CERAMIC  
LOGS

#### Specification

Visual Dimensions: mm	H 397 x W 1802 x D 220
Heat Output	1.0kW – 2.0kW
Model Number	Custom Oak Logs EDXB18RE Resin Bonded Oak Logs EDXR18RE Ceramic Logs EDXL18RE





## DLX 1600

### Electriflame Built-In 3 Sided Glass Smart Fire

#### Features

- Glass Fronted Fire
- Multi Flame Projection Technology®
- Living Ember Bed Technology®
- Flame Speed Control
- Natural Oak Logs & Woodland Ceramic Logs
- Bark chippings
- 16 pre-set colours/100+ custom/Animation mode
- LED brightness control
- Thermostatic remote & manual control operation
- CELSI App controllable. iOS & Android
- Amazon Alexa and Google Assistant compatible
- Side blanking for 2 & 1 sided installations



Celsi Smart Fires have 16 pre-set ambient colour modes, and over 100+ multi colour combinations to customise the light ambience on flames, logs, and ember bed. To simplify your choice relax and enjoy a slow cycle through the colour spectrum in our fully immersive Animation mode.

2-sided glass corner installation. Natural Oak Logs. Ceramic Logs page 13, or scan the QR code below.



NATURAL  
OAK LOGS



CERAMIC  
LOGS

#### Specification

Visual Dimensions: mm	H 397 x W 1602 x D 220
Heat Output	1.0kW – 2.0kW
Model Number	Custom Oak Logs EDXB16RE Resin Bonded Oak Logs EDXR16RE Ceramic Logs EDXL16RE



#### CELSI SMART APP

Feature-rich and simple to operate. Control your fire from your smart phone or tablet with full handset functionality.







## DLX 1250

### Electriflame Built-In 3 Sided Smart Fire

#### Features

- Glass Fronted Fire
- Multi Flame Projection Technology®
- Living Ember Bed Technology®
- Natural Oak Logs & Woodland Ceramic Logs
- Bark chippings
- 16 pre-set colours/100+ custom/Animation mode
- LED brightness control
- Thermostatic remote & manual control operation
- CELSI App controllable. iOS & Android
- Amazon Alexa and Google Assistant compatible
- Side blanking for 2 & 1 sided installations



Celsi Smart Fires have 16 pre-set ambient colour modes, and over 100+ multi colour combinations to customise the light ambience on flames, logs, and ember bed. To simplify your choice relax and enjoy a slow cycle through the colour spectrum in our fully immersive Animation mode.



#### CELSI SMART APP

Feature-rich and simple to operate. Control your fire from your smart phone or tablet with full handset functionality.

3-sided glass installation. Natural Oak Logs. Ceramic Logs page 13, or scan the QR code below.



NATURAL  
OAK LOGS



CERAMIC  
LOGS

#### Specification

Visual Dimensions: mm	H 397 x W 1252 x D 220
Heat Output	1.0kW – 2.0kW
Model Number	Custom Oak Logs EDXB12RE Resin Bonded Oak Logs EDXR12RE Ceramic Logs EDXL12RE





## DLX 1000

### Electriflame Built-In 3 Sided Smart Fire

#### Features

- Glass Fronted Fire
- Multi Flame Projection Technology®
- Living Ember Bed Technology®
- Flame Speed Control
- Natural Oak Logs
- Bark chippings
- 16 pre-set colours/100+ custom/Animation mode
- LED brightness control
- Thermostatic remote & manual control operation
- CELSI App controllable. iOS & Android
- Amazon Alexa and Google Assistant compatible
- Side blanking for 2 & 1 sided installations



Celsi Smart Fires have 16 pre-set ambient colour modes, and over 100+ multi colour combinations to customise the light ambience on flames, logs, and ember bed. To simplify your choice relax and enjoy a slow cycle through the colour spectrum in our fully immersive Animation mode.



3-sided glass installation. Natural Oak Logs.



VIDEO

#### Specification

Visual Dimensions: mm	H 397 x W 1003 x D 220
Heat Output	1.0kW – 2.0kW
Model Number	Custom Oak Logs EDXB10RE Resin Bonded Oak Logs EDXR10RE



#### CELSI SMART APP

Feature-rich and simple to operate. Control your fire from your smart phone or tablet with full handset functionality.





## DLX 750

### Electriflame Wall Inset Smart Fire

#### Features

- Glass Fronted Fire
- Multi Flame Projection Technology®
- Living Ember Bed Technology®
- Flame Speed Control
- Woodland Ceramic Logs
- 16 pre-set colours/100+ custom/Animation mode
- LED brightness control
- Thermostatic remote & manual control operation
- CELSI App controllable. iOS & Android
- Amazon Alexa and Google Assistant compatible



Celsi Smart Fires have 16 pre-set ambient colour modes, and over 100+ multi colour combinations to customise the light ambience on flames, logs, and ember bed. To simplify your choice relax and enjoy a slow cycle through the colour spectrum in our fully immersive Animation mode.



#### Specification

Visual Dimensions: mm	H 490 x W 770 x D 140
Heat Output	0.75kW – 1.5kW
Model Number	EDLXALRE-750



#### CELSI SMART APP

Feature-rich and simple to operate. Control your fire from your smart phone or tablet with full handset functionality.



Video



Black Nickel & Black.



Black Nickel & Chrome.

## DLX Vader 750

Electriflame Wall Inset Smart Fire

### Features

- Glass Fronted Fire
- Multi Flame Projection Technology®
- Living Ember Bed Technology®
- Flame Speed Control
- Woodland Ceramic Logs
- 16 pre-set colours/100+ custom/Animation mode
- LED brightness control
- Thermostatic remote & manual control operation
- CELSI App controllable. iOS & Android
- Amazon Alexa and Google Assistant compatible



Celsi Smart Fires have 16 pre-set ambient colour modes, and over 100+ multi colour combinations to customise the light ambience on flames, logs, and ember bed. To simplify your choice relax and enjoy a slow cycle through the colour spectrum in our fully immersive Animation mode.



### CELSI SMART APP

Feature-rich and simple to operate. Control your fire from your smart phone or tablet with full handset functionality.



### Specification

Fascia Dimensions: mm	H 683 x W 963 x D 21
Heat Output	0.75kW – 1.5kW
Model Number	Black Nickel & Black CEULALRE-BNB Black Nickel & Chrome CEULALRE-BNC



Video



Video





## DLX 600XT

### Electriflame Wall Inset Smart Fire

#### Features

- Glass Fronted Fire
- Multi Flame Projection Technology®
- Living Ember Bed Technology®
- Flame Speed Control
- Woodland Ceramic Logs
- 16 pre-set colours/100+ custom/Animation mode
- LED brightness control
- Thermostatic remote & manual control operation
- CELSI App controllable. iOS & Android
- Amazon Alexa and Google Assistant compatible



Celsi Smart Fires have 16 pre-set ambient colour modes, and over 100+ multi colour combinations to customise the light ambience on flames, logs, and ember bed. To simplify your choice relax and enjoy a slow cycle through the colour spectrum in our fully immersive Animation mode.



#### Specification

Visual Dimensions: mm	H 562 x W 570 x D 140
Heat Output	0.75kW – 1.5kW
Model Number	EDLXASRE-6XT



#### CELSI SMART APP

Feature-rich and simple to operate. Control your fire from your smart phone or tablet with full handset functionality.



Video



Black Nickel & Chrome fascia.



Video

**Specification**

Fascia Dimensions: mm	H 768 x W 762 x D 19
Heat Output	0.75kW – 1.5kW
Model Number	CEULASRE-FAS



**CELSI SMART APP**

Feature-rich and simple to operate. Control your fire from your smart phone or tablet with full handset functionality.

**DLX 600XT**

Electriflame Wall Inset Smart Fire

**Features**

- Glass Fronted Fire
- Multi Flame Projection Technology®
- Living Ember Bed Technology®
- Flame Speed Control
- Woodland Ceramic Logs
- 16 pre-set colours/100+ custom/Animation mode
- LED brightness control
- Thermostatic remote & manual control operation
- CELSI App controllable. iOS & Android
- Amazon Alexa and Google Assistant compatible



Celsi Smart Fires have 16 pre-set ambient colour modes, and over 100+ multi colour combinations to customise the light ambience on flames, logs, and ember bed. To simplify your choice relax and enjoy a slow cycle through the colour spectrum in our fully immersive Animation mode.







## DLX 600

### Electriflame Wall Inset Smart Fire

#### Features

- Glass Fronted Fire
- Multi Flame Projection Technology®
- Living Ember Bed Technology®
- Flame Speed Control
- Woodland Ceramic Logs
- 16 pre-set colours/100+ custom/Animation mode
- LED brightness control
- Thermostatic remote & manual control operation
- CELSI App controllable. iOS & Android
- Amazon Alexa and Google Assistant compatible



Celsi Smart Fires have 16 pre-set ambient colour modes, and over 100+ multi colour combinations to customise the light ambience on flames, logs, and ember bed. To simplify your choice relax and enjoy a slow cycle through the colour spectrum in our fully immersive Animation mode.



Woodland Ceramic Logs. Trimless.



Video

#### Specification

Visual Dimensions: mm	H 447 x W 565 x D 140
Heat Output	0.75kW – 1.5kW
Model Number	EDLX22RE-600



#### CELSI SMART APP

Feature-rich and simple to operate. Control your fire from your smart phone or tablet with full handset functionality.



## DLX Impulse 600

Electriflame Wall Inset Smart Fire

### Features

- Glass Fronted Fire
- Multi Flame Projection Technology®
- Living Ember Bed Technology®
- Flame Speed Control
- Woodland Ceramic Logs
- 16 pre-set colours/100+ custom/Animation mode
- LED brightness control
- Thermostatic remote & manual control operation
- CELSI App controllable. iOS & Android
- Amazon Alexa and Google Assistant compatible



Celsi Smart Fires have 16 pre-set ambient colour modes, and over 100+ multi colour combinations to customise the light ambience on flames, logs, and ember bed. To simplify your choice relax and enjoy a slow cycle through the colour spectrum in our fully immersive Animation mode.



### CELSI SMART APP

Feature-rich and simple to operate. Control your fire from your smart phone or tablet with full handset functionality.



### Specification

Fascia Dimensions: mm	H 742 x W 860 x D 60
Heat Output	0.75kW – 1.5kW
Model Number	Satin Black ED600-463 Satin Silver ED600-972



Video

Satin Black.



Video

Satin Silver.





Black Nickel & Black.



Video



**Specification**

Fascia Dimensions: mm	H 600 x W 498 x D 40
Heat Output	0.75kW – 1.5kW
Premium Board Paint Finish Smooth White & Black	Model Number EDLXBNRE



Chrome & Satin Silver



Brass & Black



Black Nickel & Chrome

**DLX Olympus**

Electriflame Hearth Inset Smart Fire

DLX Olympus redefines the art of fire illusion. This full-depth, glass-fronted design captivates with a mesmerizing interplay of exciting flame effects, thanks to Multiflame Projection® and Living Ember Bed® technology. Witness vibrant flames dancing above and around the log bed while a captivating glow emanates from beneath, mimicking the light brilliance of a real fire. Enjoy full-spectrum colors and effortless control via the feature handset, mobile phone, and tablet. Transforming your living space into a haven of warmth and ambiance.

**Features**

- Glass Fronted Fire
- Multi Flame Projection Technology®
- Living Ember Bed Technology®
- Flame Speed Control
- Woodland Ceramic Logs
- 16 pre-set colours/100+ custom/Animation mode
- LED brightness control
- Thermostatic remote & manual control operation
- CELSI App controllable. iOS & Android
- Amazon Alexa and Google Assistant compatible



**CELSI SMART APP**  
Feature-rich and simple to operate. Control your fire from your smart phone or tablet with full handset functionality.

# DLX Media Wall 1250 Suite

## Pre-Built Fire Media Wall Package

Our pre-built media wall suites are crafted in the UK using premium quality Egger boards in a choice of Cupria Slate, or Smooth White with Acoustic Oak panels. The media wall suite comes in three easy-to-assemble parts, making installation simple. Our design incorporates a log storage compartment, and a TV recessed compartment with a cut-out rear panel to flush-mount your TV.

The Suite package includes our 1250 DLX electric fire with natural Oak logs and bark chippings.

### Features

- 3-Sided Glass Smart Fire
- Multi Flame Projection Technology®
- Living Ember Bed Technology®
- Heat Output 1.0kW - 2.0kW
- Natural Oak Logs & Bark chippings
- 16 pre-set colours/100+ custom/Animation mode
- LED brightness control
- Thermostatic remote & manual control operation
- CELSI App controllable. iOS & Android
- Amazon Alexa and Google Assistant compatible



Video

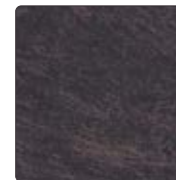

Cupria Slate



THERMO-STATIC



7 DAY TIMER



ENERGY SAVING



ISO FLAME



COLOUR SMART



REAL WOOD

### Specification

Specification	DLX Media Wall 1250
Suite Dimensions: mm	H 2200 x W 1570 x D 420
Heat Output	1.0kW – 2.0kW
Premium Board Paint Finish	Model Number
Cupria Slate	EDXB12RE-MWG
White & Acoustic Oak	EDXB12RE-MWW

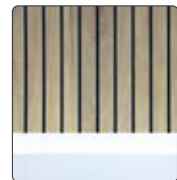

White & Acoustic Oak



Video





## DLX Monroe 1250/1000 Suite

### Electriflame 3 Sided Fire Suite

Crafted in the UK using premium quality Egger boards in Smooth White with Acoustic Oak panels. This suite comes fully assembled complete with our popular sizes 1250 or 1000 DLX Natural Oak log fires. Suite installation is as simple as placing down and plugging in.

#### Features

- 3-Sided Glass Smart Fire
- Multi Flame Projection Technology®
- Living Ember Bed Technology®
- Flame Speed Control\*
- Natural Oak Logs
- Bark chippings
- 16 pre-set colours/100+ custom/Animation mode
- LED brightness control
- Thermostatic remote & manual control operation
- CELSI App controllable. iOS & Android
- Amazon Alexa and Google Assistant compatible



\* Flame Speed Control DLX 1000

DLX Monroe 1250 Suite.



1250



1000

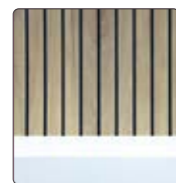

White & Acoustic Oak

#### Specification

Suite Dimensions: mm	H 397 x W 1602 x D 420
Heat Output	1.0kW – 2.0kW
Premium Board Paint Finish White & Acoustic Oak	Model Number 1250 - EDX12SRE-MSW 1000 - EDX10SRE-MSW



**CELSI SMART APP**  
Feature-rich and simple to operate. Control your fire from your smart phone or tablet with full handset functionality.





Video

**Specification**

Suite Dimensions: mm	H 990 x W 1465 x D 380
Heat Output	0.75kW – 1.5kW
Premium Board Paint Finish Smooth White	Model Number EDLXALRE-SWT

## DLX Adour 750

### Electrifiame Premier Illumia Suite

Tastefully designed and manufactured using Premier quality boards, coated with a smooth White finish. This suite features integrated natural warm LED Illumia downlights, and at the heart is the DLX 750 electric fire with innovative technology to provide an exceptional real fire experience.

This glass fronted suite benefits from a simple place-down and plug-in fuss-free installation.

**Features**

- Dimmable Surround LEDs
- Glass Fronted Fire
- Multi Flame Projection Technology®
- Living Ember Bed Technology®
- Flame Speed Control
- Woodland Ceramic Logs
- 16 pre-set colours/100+ custom/Animation mode
- LED brightness control
- Thermostatic remote & manual control operation
- CELSI App controllable. iOS & Android
- Amazon Alexa and Google Assistant compatible



**CELSI SMART APP**  
Feature-rich and simple to operate. Control your fire from your smart phone or tablet with full handset functionality.







Video

**Specification**

Suite Dimensions: mm	H 1090 x W 1340 x D 380
Heat Output	0.75kW – 1.5kW
Premium Board Paint Finish Smooth White & Black	Model Number EDLXASRE-WBS

## DLX Adour 600XT

### Electriflame Premier Illumia Suite

Tastefully designed and manufactured using Premier quality boards, coated with a smooth White and Black finish. This suite features integrated natural warm LED Illumia downlights, and at the heart is the DLX 600XT electric fire with innovative technology to provide an exceptional real fire experience.

This glass fronted suite benefits from a simple place-down and plug-in fuss-free installation.

**Features**

- Dimmable Surround LEDs
- Glass Fronted Fire
- Multi Flame Projection Technology®
- Living Ember Bed Technology®
- Flame Speed Control
- Woodland Ceramic Logs
- 16 pre-set colours/100+ custom/Animation mode
- LED brightness control
- Thermostatic remote & manual control operation
- CELSI App controllable. iOS & Android
- Amazon Alexa and Google Assistant compatible



**CELSI SMART APP**  
Feature-rich and simple to operate. Control your fire from your smart phone or tablet with full handset functionality.





Textured White.



Video

**Specification**

Suite Dimensions: mm	H 835 x W 1185 x D 360
Heat Output	0.75kW – 1.5kW
Premium Board Paint Finish	Model Number
Textured White & Black	EDLXTSRE-TWH
Smooth White	EDLXTSRE-SWT
Textured Black & White	EDLXTSRE-TBW



Smooth White.



Textured Black & White.



**DLX Toronto 600**

Electrifiame Premier Illumia Suite

Tastefully designed and manufactured using Premier quality boards, coated with a smooth White finish. This suite features integrated natural warm LED Illumia downlights, and at the heart is the DLX 750 electric fire with innovative technology to provide an exceptional real fire experience.

This glass fronted suite benefits from a simple place-down and plug-in fuss-free installation.

**Features**

- Dimmable Surround LEDs
- Glass Fronted Fire
- Multi Flame Projection Technology®
- Living Ember Bed Technology®
- Flame Speed Control
- Woodland Ceramic Logs
- 16 pre-set colours/100+ custom/Animation mode
- LED brightness control
- Thermostatic remote & manual control operation
- CELSI App controllable. iOS & Android
- Amazon Alexa and Google Assistant compatible



THERMOSTATIC



7 DAY TIMER



ENERGY SAVING



ISO FLAME



COLOUR SMART



FLAME SPEED



**CELSI SMART APP**

Feature-rich and simple to operate. Control your fire from your smart phone or tablet with full handset functionality.



# DLX Aleesia 750

## Electriflame Limestone Illumia Suite

The DLX Aleesia Suite features a stunning Portuguese Limestone surround with integrated warm natural LED downlights, housing the contemporary DLX 750 glass fronted Smart electric fire that captivates with a mesmerizing interplay of light and shadow, thanks to Multiflame Projection® and Living Ember Bed® technology. Witness the vibrant flames dancing above the log bed while a captivating glow emanates from beneath, mimicking the heart of a real fire.

This suite is available in 58, and 54 inch widths to accommodate a smaller room, or a narrow chimney breast.

### Features

- Dimmable Surround LEDs
- Glass Fronted Fire
- Multi Flame Projection Technology®
- Living Ember Bed Technology®
- Flame Speed Control
- Woodland Ceramic Logs
- 16 pre-set colours/100+ custom/Animation mode
- LED brightness control
- Thermostatic remote & manual control operation
- CELSI App controllable. iOS & Android
- Amazon Alexa and Google Assistant compatible
- Two sizes available, 54" & 58" wide



### CELSI SMART APP

Feature-rich and simple to operate. Control your fire from your smart phone or tablet with full handset functionality.



Video

### Specification

Suite Dimensions: mm	54" 58"	H 1050 x W 1370 x D 400 H 1050 x W 1470 x D 400
Heat Output	0.75kW – 1.5kW	
Natural Limestone	Model Number 54" CEULAL54RE 58" CEULAL58RE	

# DLX Asencio 600XT

## Electriflame Limestone Suite

A beautiful contemporary Portuguese Limestone surround paired with the DLX 600XT electric fire. This innovative technology provides a deep fuel bed with supremely detailed ceramics capturing the authentic shape and texture of natural logs placed over a perception of hot ash embers. At the touch of a button this fire creates beautiful flowing flames and relaxing comfortable warmth, much as you would expect from a natural fire experience. For a modern and elegant electric fireplace, enhancing your living space, creating a relaxing home lifestyle.

### Features

- Glass Fronted Fire
- Multi Flame Projection Technology®
- Living Ember Bed Technology®
- Flame Speed Control
- Woodland Ceramic Logs
- 16 pre-set colours/100+ custom/Animation mode
- LED brightness control
- Thermostatic remote & manual control operation
- CELSI App controllable. iOS & Android
- Amazon Alexa and Google Assistant compatible



**CELSI SMART APP**  
Feature-rich and simple to operate. Control your fire from your smart phone or tablet with full handset functionality.



Video

### Specification

Suite Dimensions: mm	H 1095 x W 1376 x D 380
Heat Output	0.75kW – 1.5kW
Natural Limestone	Model Number CEULASSRE



# DLX Angelo 600

## Electriflame Limestone Suite

DLX Angelo Suite features a stunning Portuguese Limestone surround, housing the contemporary DLX 600 glass fronted electric fire. This innovative technology provides a deep fuel bed with supremely detailed ceramics that capture the authentic shape and texture of natural logs placed over a perception of hot ash embers.

For a modern and elegant electric fireplace, this suite will elevate your living space and create a tranquil home atmosphere.

### Features

- Glass Fronted Fire
- Multi Flame Projection Technology®
- Living Ember Bed Technology®
- Flame Speed Control
- Woodland Ceramic Logs
- 16 pre-set colours/100+ custom/Animation mode
- LED brightness control
- Thermostatic remote & manual control operation
- CELSI App controllable. iOS & Android
- Amazon Alexa and Google Assistant compatible



### CELSI SMART APP

Feature-rich and simple to operate. Control your fire from your smart phone or tablet with full handset functionality.



Video

### Specification

Suite Dimensions: mm	H 1070 x W 1370 x D 380
Heat Output	0.75kW – 1.5kW
Natural Limestone	Model Number CEULLIRE-RGB

# DLX Boticelli 600

## Electriflame Limestone Suite

The DLX Boticelli Suite features a stunning Portuguese Limestone surround housing the contemporary DLX 600 inset Smart electric fire. This fire comes with Smart connection capability and innovative technology. The fuel effect consists of realistic natural flame, and authentically designed woodland logs placed over a blaze underbed living embers. The flame speed can be easily controlled to suit your desired mood and preference.

At the touch of a button this fire creates beautiful flowing flames and relaxing comfortable warmth. This highly stylish and artistic combination delivers luxury and performance with built-in Smart technology.

### Features

- Glass Fronted Fire
- Multi Flame Projection Technology®
- Living Ember Bed Technology®
- Flame Speed Control
- Woodland Ceramic Logs
- 16 pre-set colours/100+ custom/Animation mode
- LED brightness control
- Thermostatic remote & manual control operation
- CELSI App controllable. iOS & Android
- Amazon Alexa and Google Assistant compatible



### CELSI SMART APP

Feature-rich and simple to operate. Control your fire from your smart phone or tablet with full handset functionality.



Video

### Specification

Suite Dimensions: mm	H 1060 x W 1370 x D 380
Heat Output	0.75kW – 1.5kW
Natural Limestone	Model Number CEULAVRE-RGB



# DLX Pablo 600

## Electriflame Limestone Suite

The DLX Pablo Suites' straight lines and sleek design present a more modern electric fireplace appearance. This well-proportioned surround is made from the finest quality Portuguese limestone and comes with the DLX 600 glass fronted electric fire. The fire comes with Smart connection capability and innovative technology. The fuel effect consists of realistic natural flame, and authentically designed woodland logs placed over a blaze underbed living embers. The flame speed can be easily controlled to suit your desired mood and preference.

Smart performance, modern and simple styling with clean looks, that's the DLX Pablo Suite, and it's sure to make the right impressions in your home

### Features

- Glass Fronted Fire
- Multi Flame Projection Technology®
- Living Ember Bed Technology®
- Flame Speed Control
- Woodland Ceramic Logs
- 16 pre-set colours/100+ custom/Animation mode
- LED brightness control
- Thermostatic remote & manual control operation
- CELSI App controllable. iOS & Android
- Amazon Alexa and Google Assistant compatible



### CELSI SMART APP

Feature-rich and simple to operate. Control your fire from your smart phone or tablet with full handset functionality.



Video

### Specification

Suite Dimensions: mm	H 1060 x W 1370 x D 380
Heat Output	0.75kW – 1.5kW
Natural Limestone	Model Number CEULRSRE-RGB

# FIRE DIMENSIONS

Measurements in millimetres

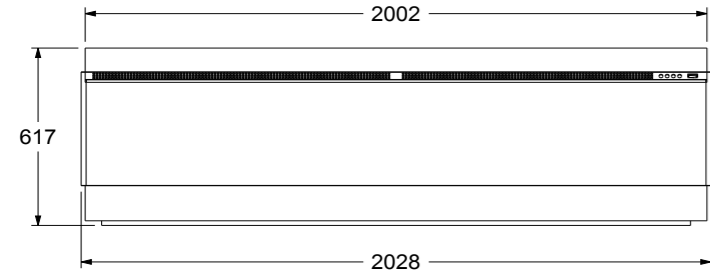

DLX 2000

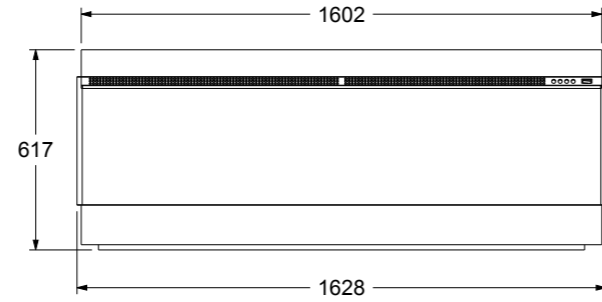

DLX 1600

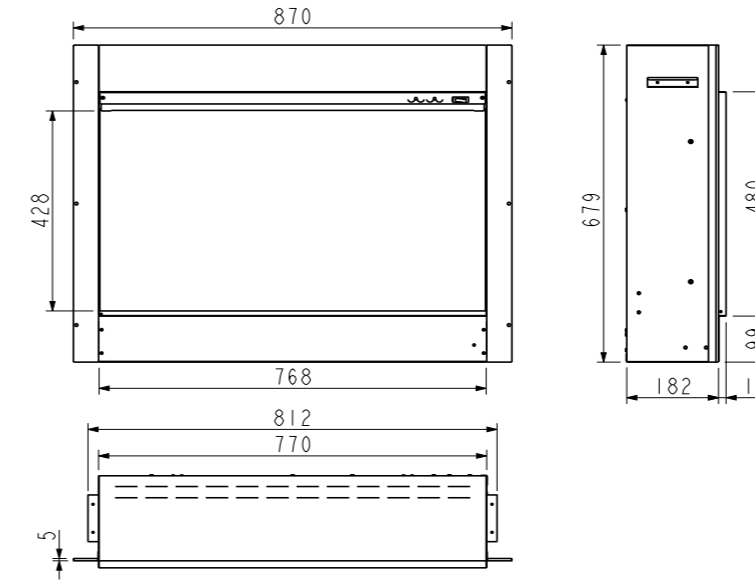

DLX 750

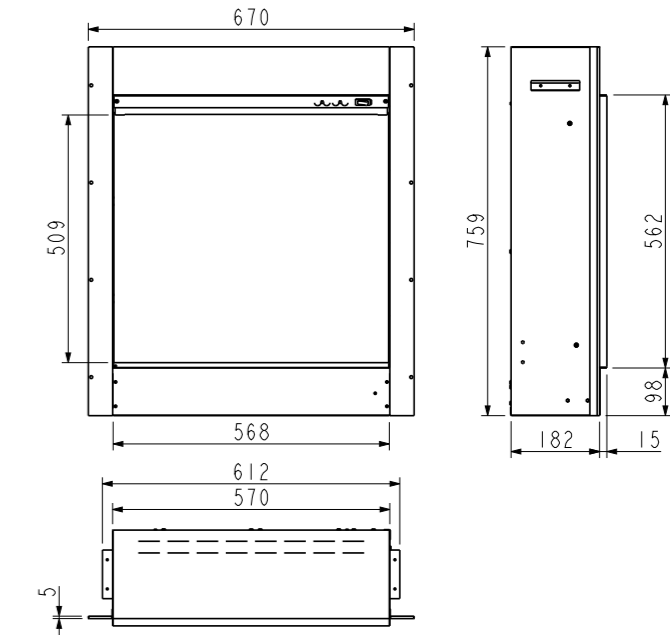

DLX 600XT

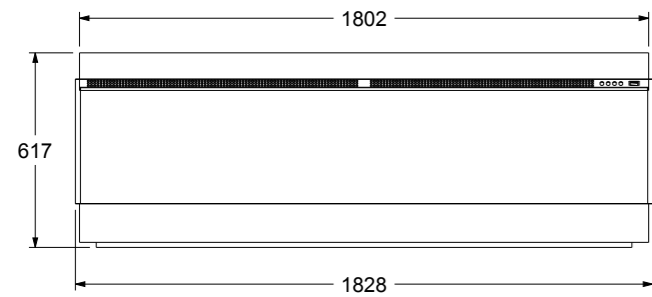

DLX 1800

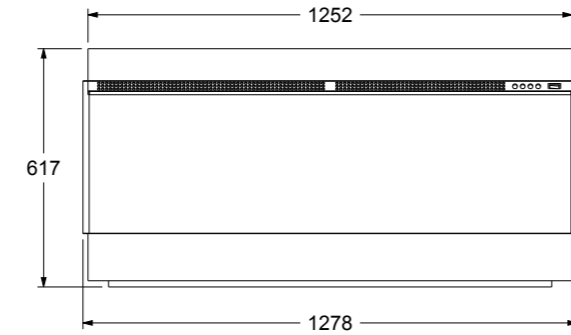

DLX 1250

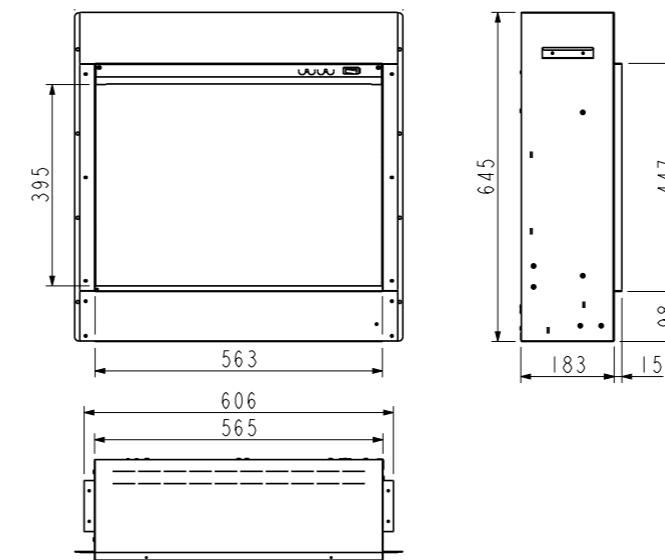

DLX 600

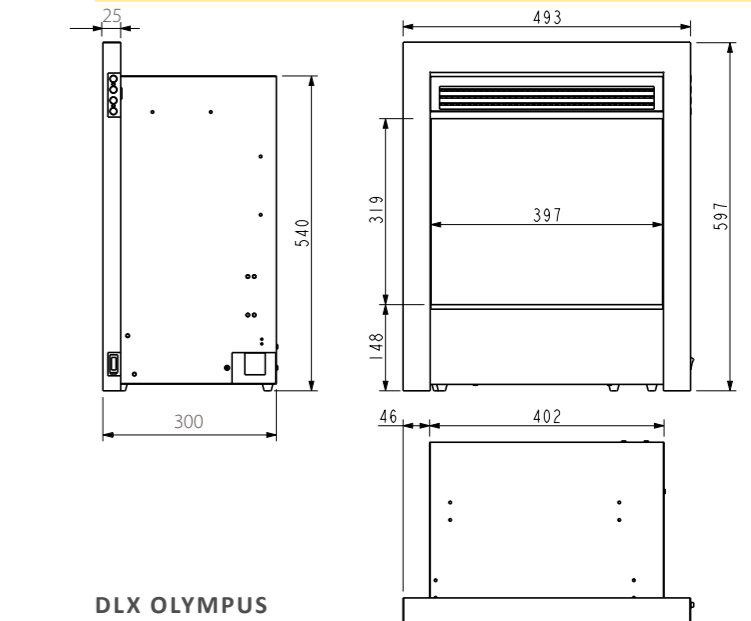

DLX OLYMPUS

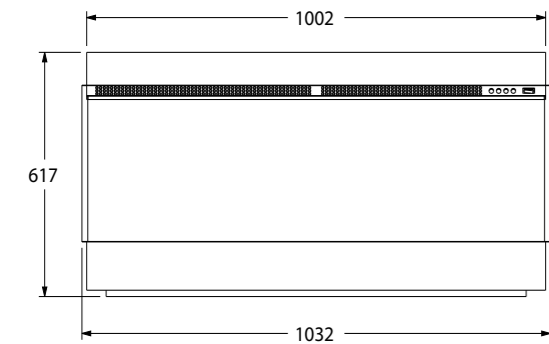

DLX 1000

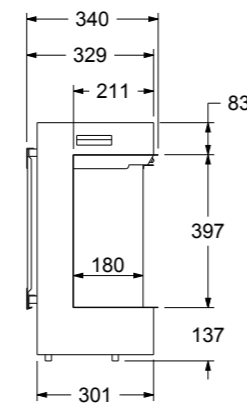

ALL MODELS



## FIRE DIMENSIONS

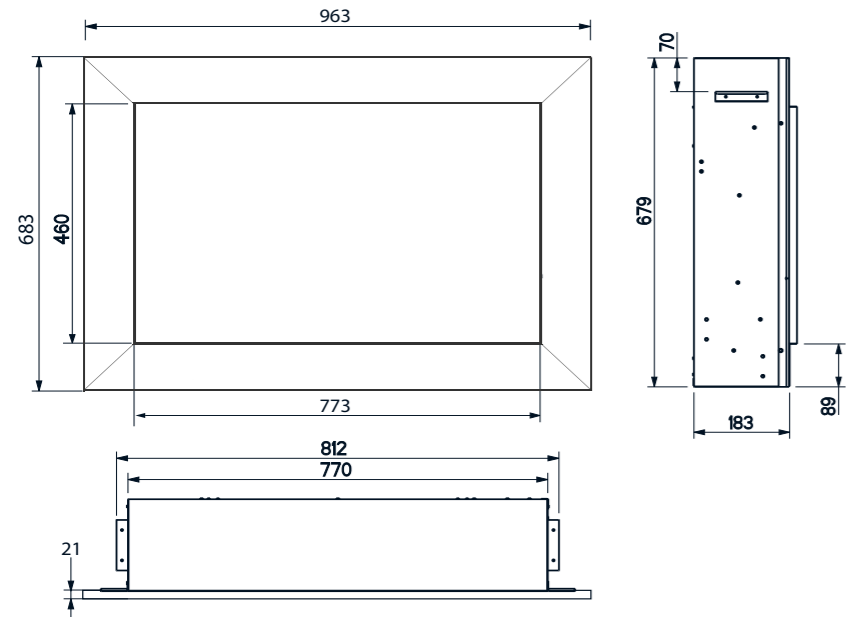

DLX VADER 750

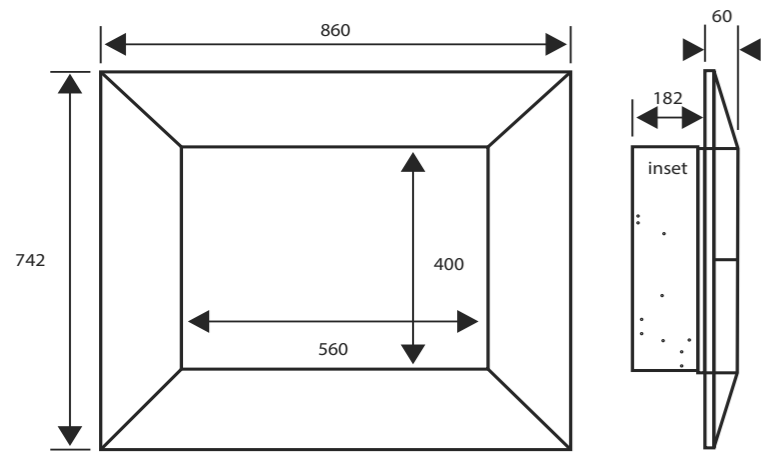

DLX IMPULSE 600

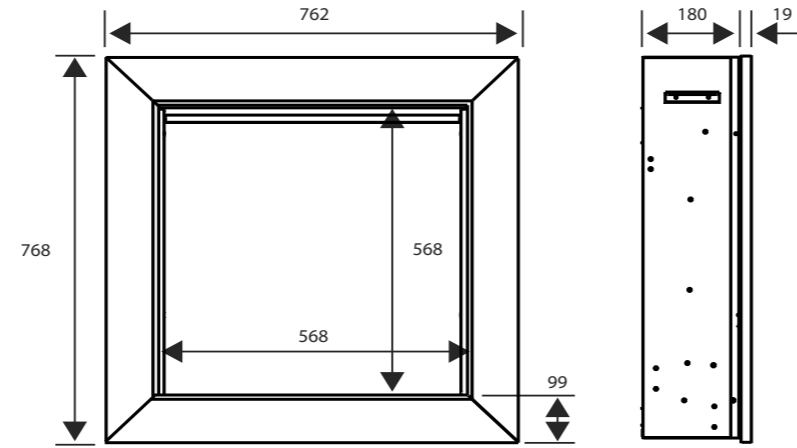

DLX EVORA 600XT

## SUITE DIMENSIONS

Measurements in millimetres

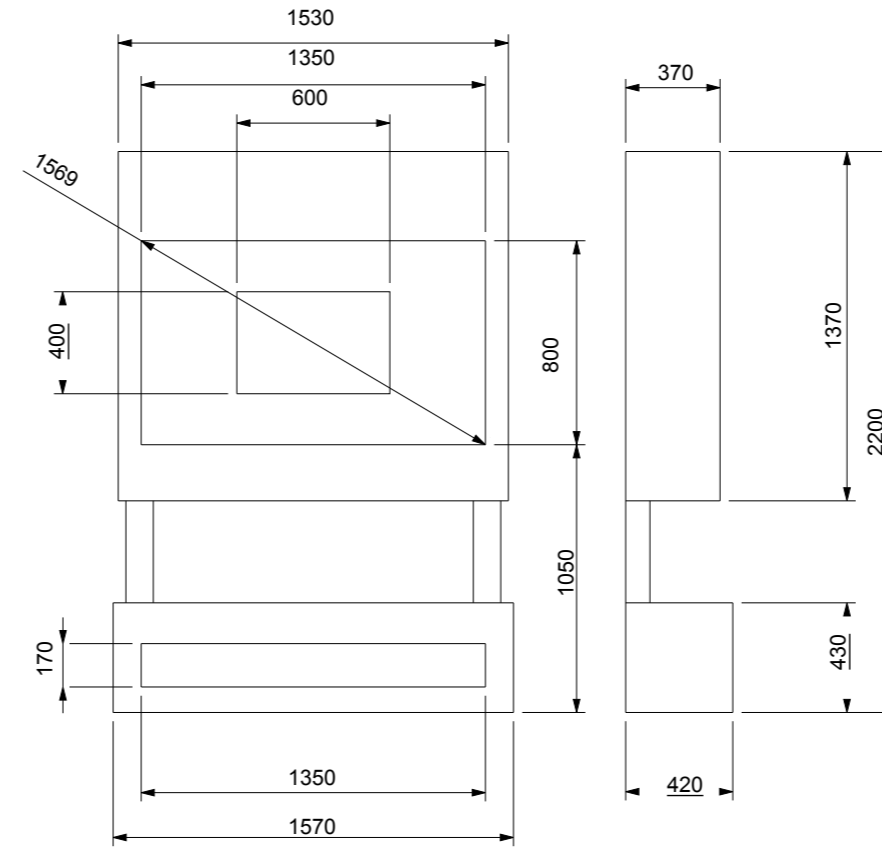

DLX MEDIA WALL 1250 SUITE

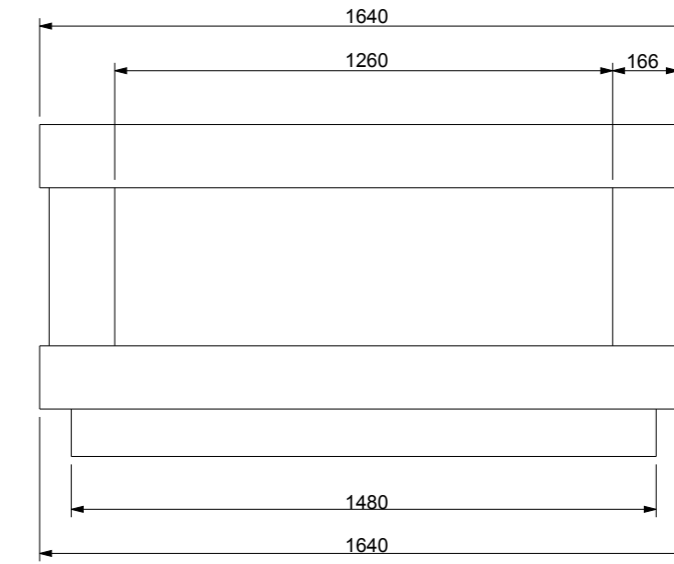

DLX MONROE 1250 SUITE

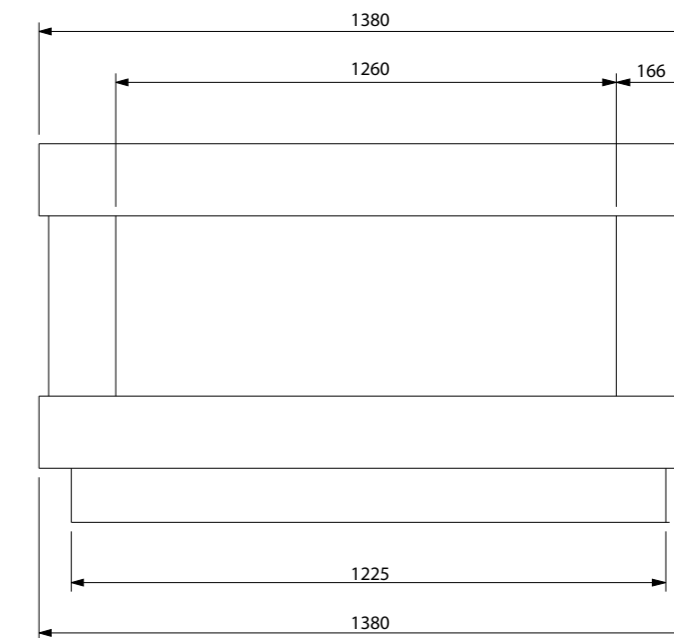

DLX MONROE 1000 SUITE

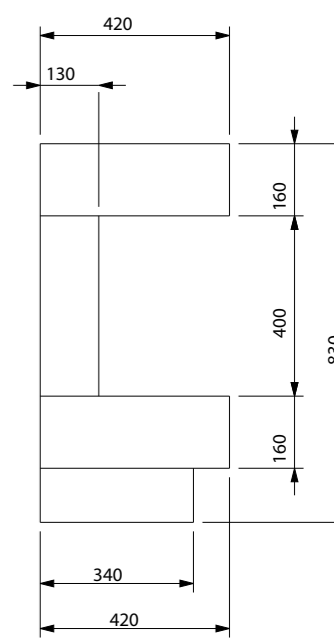
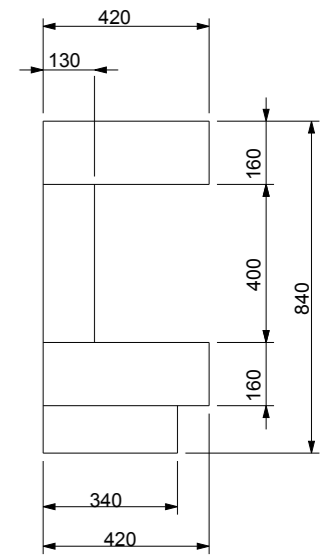

# SUITE DIMENSIONS

Measurements in millimetres

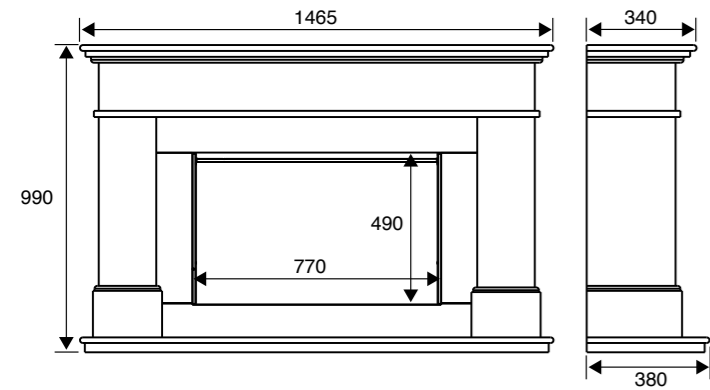

DLX ADOUR 750 SUITE

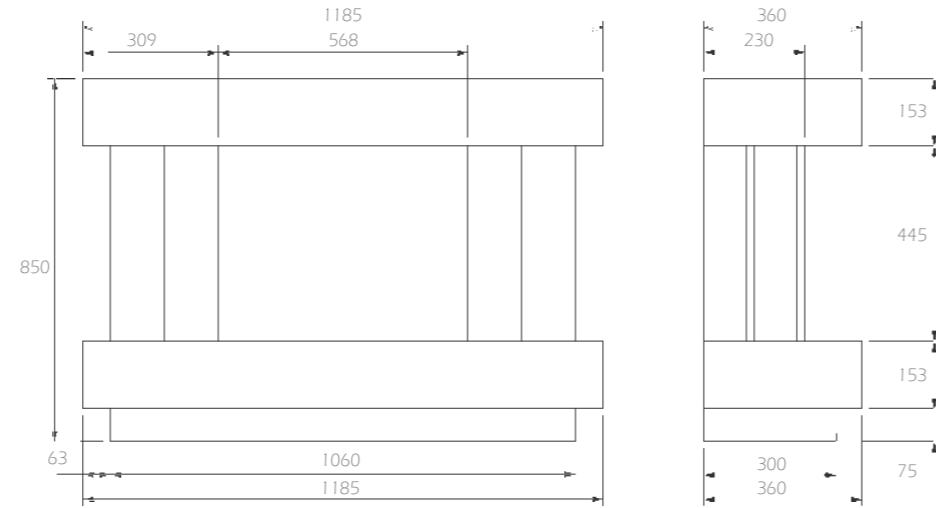

DLX TORONTO 600 SUITE

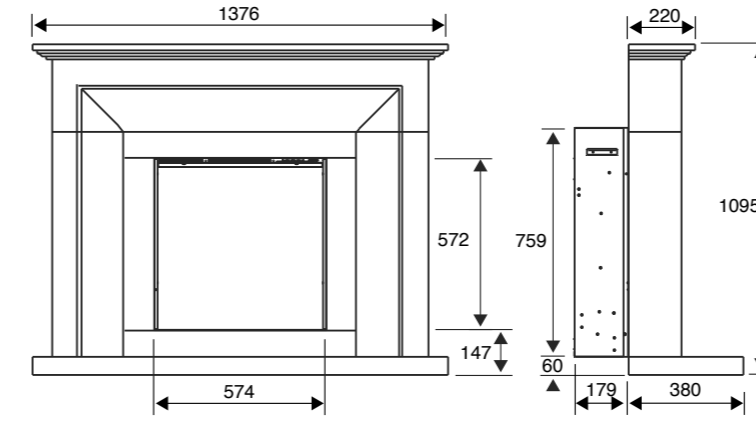

DLX ASENCIO 600XT SUITE

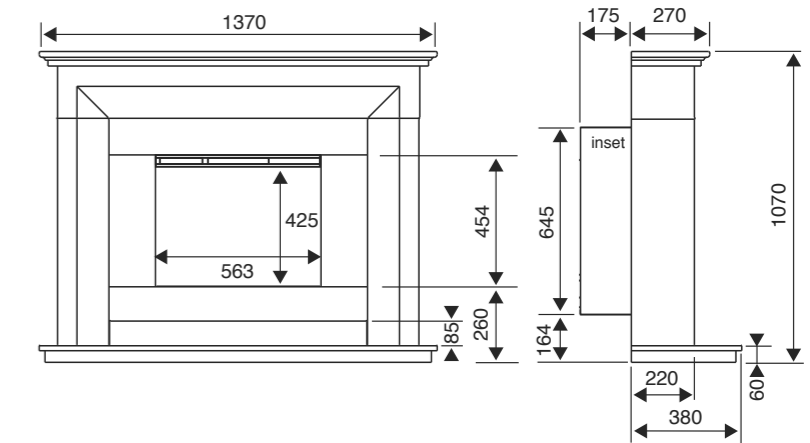

DLX ANGELO 600 SUITE

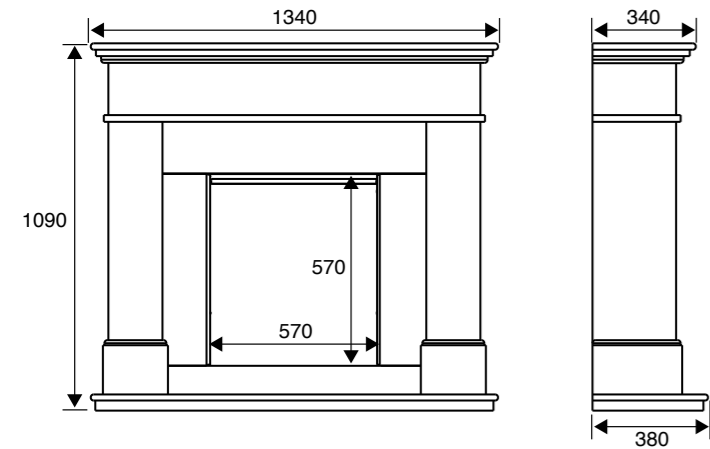

DLX ADOUR 600XT SUITE

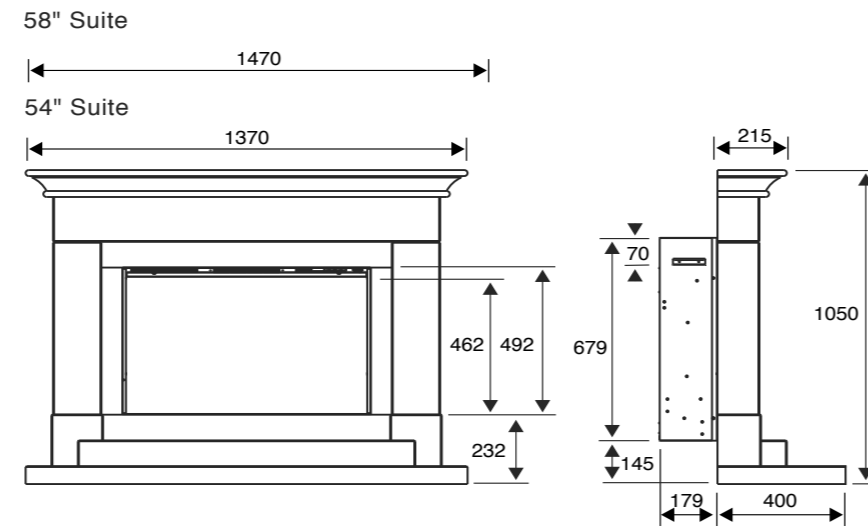

DLX 750 SUITE

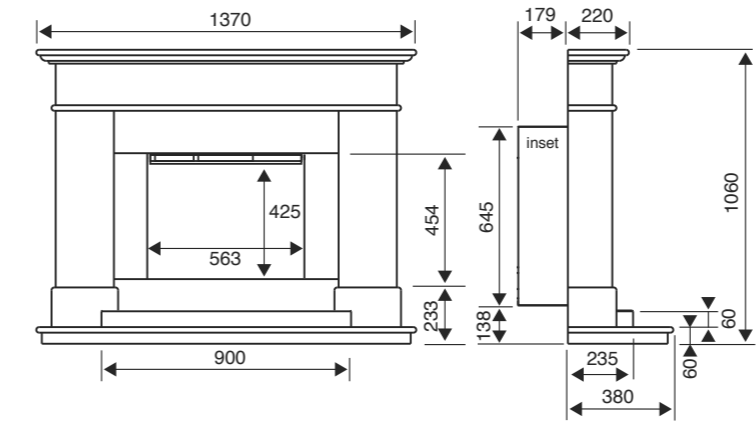

DLX BOTICELLI 600 SUITE

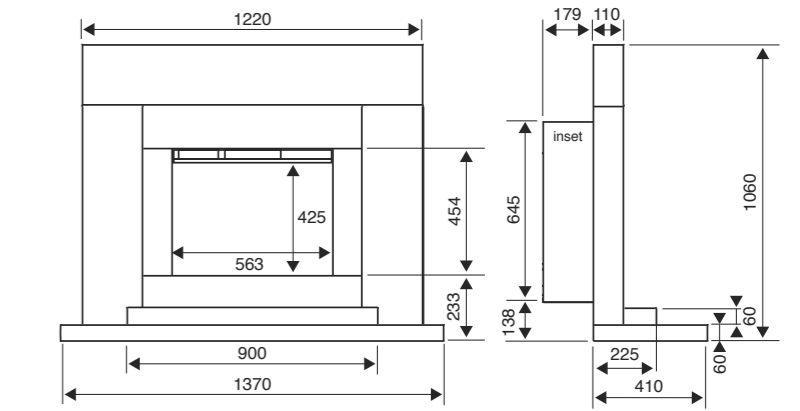

DLX PABLO 600 SUITE





[www.celsielectricfires.co.uk](http://www.celsielectricfires.co.uk)

Go direct to the Celsi website on your smart phone or tablet device and use the app to scan the black and white QR codes shown on each page. Alternatively, go to [www.celsielectricfires.co.uk](http://www.celsielectricfires.co.uk) to browse all Celsi electric fires.



BFM Europe Ltd, Gordon Banks Drive, Trentham Lakes, Stoke-on-Trent ST4 4TJ  
Tel:01782 339000 Email: [sales@bfm-europe.com](mailto:sales@bfm-europe.com)

#### DISCLAIMER

Our policy is one of constant development and improvement. We therefore reserve the right to revise designs and specifications of our products without formal notice, patents pending. We always recommend our products to be viewed in an approved showroom before purchase. Whilst we have taken every care in the preparation of this brochure it is not intended to replace the installation manual which provides more detailed information.

Photography is for illustration purposes only and although every effort has been made to ensure accurate reproduction of typical installations and flame pictures they may vary according to fire model and installation methods.

We recommend that all our fires are used in conjunction with central heating and not as a primary source of heat. In the interests of personal safety a suitable fireguard is recommended when children, the elderly and the infirm are present.

We accept no liability for any loss or damage arising directly or indirectly from the use of this brochure. This brochure is copyright 2023 and must not be reproduced in whole or in any part without prior written permission.

