

CELSI
...the future of fire



PREMIUM ELECTRIC FIRES 2024

DEFINED | BY | EXCELLENCE

SHOWROOM EXCLUSIVE





WELCOME TO CELSI



At Celsi we know how important it is to create a stylish and relaxing living environment. That's why we've developed this collection of premium electric fires.

This brochure has been designed to make the purchase of your new Celsi fire as simple as possible. I hope you find it both informative and inspiring.



SHOWROOM EXCLUSIVE

Electriflame DLX products provide all the warmth, comfort, and style to be expected from high-performance electric fires. Our showroom network of independent retailers is exclusively selected to display our products. These highly experienced retailers can demonstrate all the features and benefits of owning a DLX fire. A retailer can provide guidance for your individual requirements, and assist you with choosing and installing the most appropriate model for your home.

We want you to experience the very best product performance, customer care, and service satisfaction that we believe you will find from our CELSI DLX retailers.



PEACE OF MIND ASSURANCE

We believe our success stems from a combination of innovative design, investment in technology and the highest quality manufacturing standards. To reflect our belief in their quality and durability, Celsi DLX fires carry a 5 year warranty, subject to terms and conditions.



Through design innovation and precision engineering Celsi have captured every natural element and characteristic that embodies fire. This has been stunningly reproduced and encased behind safe-to-touch sleek glass walls.

CONTENTS

SMART FUNCTIONALITY	6-7
ADVANCED FEATURES	8-9
ART OF TRANSFORMATION	10-11
NATURAL WOOD & CERAMIC LOGS	12-13

NATURAL OAK FIRES	14-21
WOODLAND CERAMIC FIRES	22-29
MEDIA WALL & SUITES	30-33

DIMENSIONS	34-35
------------	-------

SMART FUNCTIONALITY



Electrifiame DLX is a new generation of electric fires featuring automatic systems and user-interactive controls. With the Celsi Smart App functionality is at your fingertips, you can effortlessly control everything from your smartphone or tablet, from thermostatic programmable heating to vibrant fire displays.

Unwind as the soft glow of your fire transitions seamlessly through the full colour spectrum with our immersive Animation mode. This gentle cycling of hues creates a calming atmosphere, adding an extra layer of relaxation and elegance to your space. Whether you're looking to set the perfect mood or simply enjoy the vibrant interplay of light, Animation mode offers a captivating experience.



ELECTRIFLAME®DLX COLOUR CONTROL.



COLOUR

Enjoy 16 pre-set ambient colour modes and over 100 multi-colour combinations to customize the flames, logs, and embers. LED lights above, beneath, and behind the fuel bed create the illusion of hot embers, burning logs, and tall flames for a real fire experience.



Operated via Celsi Smart handset and Celsi Smart App.

CONNECTIVITY

Get connected with our feature-rich and simple to operate CELSI Smart App. Available to download on the App Store, or get in on Google Play!

CONTROL

Control your fire from your smart phone or tablet with full handset functionality.



Further applied smart technology allows you to voice activate your fire using Amazon Alexa and Google Assistant.



Scan the QR code to download our App.



Celsi Smart app control

ADVANCED FEATURES

Experience the warmth and ambiance of a DLX fire all year round, effortlessly operated to suit even the busiest lifestyles. When it's time for comfort and relaxation our premium heating system quietly emits warm air, letting you enjoy beautiful flames in peace with minimal operational noise.

One of many advanced features in our DLX fires is ISOFLAME, which allows independent flame operation when no heat is required. Celsi integrates the finest industry-designed features, ensuring optimal energy-saving performance and assurance. Please take a moment to explore our Advanced Features section.



Minimal operational noise. Quiet warmth, complete control.

Optimal energy saving performance and assurance.

Our fires are built with high quality low energy consumption LEDs that provide incredible flame brightness and colour saturation, whilst maintaining sensible and economical energy use.



THERMOSTATIC HEATING

Pre-set your heat comfort level for automatic temperature control via the handset.



TIMER FUNCTION

Programmable 7-day heating timer with hourly on/off control.



LED EFFICIENCY

Advanced lighting is used throughout our product. Our onboard LED's ensure effective energy saving low power consumption.



ISOFLAME

Independent flame effect capable of displaying in isolation when no heat is required from the appliance.



COLOUR SMART

16 colour vibrant presets with 100+ options to customise the light ambiance on flames, logs, and ember bed.



Compliance with Electrical Energy Rated Product (ERP)
Integrated design features for optimal energy saving performance and assurance.



Conformity assessed and certified UK & EU



Celsi Smart handset.

ART OF TRANSFORMATION

DLX fires have the power to transform a room, crafted to complement any home, regardless of size. Whether you're adding one of our on-trend media wall units or renovating an existing chimney breast, we offer four product sizes, with our largest model measuring an impressive 2 meters.

CONFIGURATION

Desirable results can be achieved with the number of installation possibilities available. Our fires are supplied with side blanking panels giving you the option to customise your installation by choosing a full aspect 3-sided glass fire, a 2-sided left or right configuration, or to simply install as a single glass fronted wall inset fire.

For more advice and to explore installation options tailored to your home, visit a Celsi DLX showroom. Our knowledgeable retailers will provide expert guidance and demonstrate the full range of our products, helping you make the perfect choice.



3-sided glass installation.



2-sided glass installation.



1-sided glass installation.

MOOD LIGHTING

Enhance your feature wall transformation by adding color-changing LED lighting through the USB port on your DLX fire. This option is perfect for creating ambient mood lighting and adds a stylish design element to your home.

For comprehensive advice on integrating ambient mood lighting with your DLX fire, visit your nearest Celsi retailer. They can offer expert guidance tailored to your specific design and installation preferences.

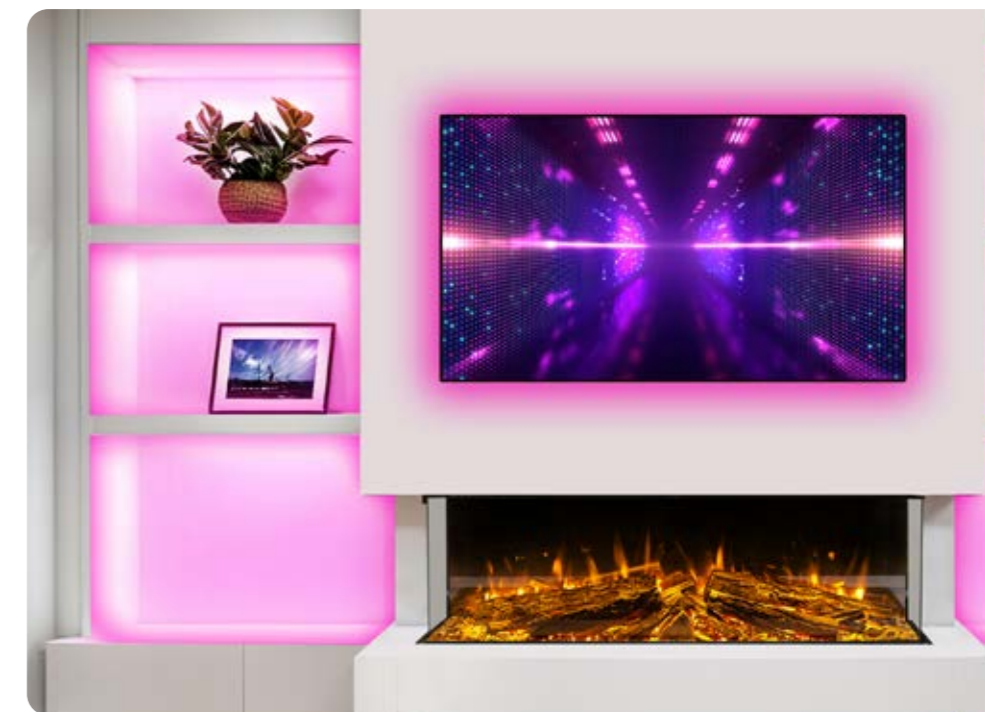

FIRE TO TV SIZE

Finding the right balance between fire and TV size is key when designing a Media wall. As televisions have grown larger, so have our fireplaces. Large TVs are often mounted or inset above the fireplace, raising the question: what sizes work best together?

To help, we offer a 'recommended size guide' that takes the diagonal TV measurement into account. This guide ensures the fireplace is slightly wider than the TV, creating a balanced and visually pleasing result for your space.

Fire size	TV Diagonal	TV Width
Millimetres	Inches	Millimetres
DLX 1250	(55)	1227
DLX 1600	(65)	1455
DLX 1800	(75)	1675
DLX 2000	(85)	1911

NATURAL OAK LOGS

DLX 3-sided fires combine sensational flame effects with genuine oak logs, each split to reveal the unique character of the oak. Chosen for its deep rich color and distinctive textured bark, hardwood oak provides a beautiful natural finish for these premium electric fires.

Our pre-assembled resin-bonded fuelbed is meticulously handcrafted by skilled artisans. They split and sculpt high-quality oak, selectively flame-charring the logs and chippings to develop wood-burning character. These made-to-measure log-sets offer a simple and efficient installation solution.

Alternatively, you may choose our loose oak logs arrangement, each log carefully wrapped and individually referenced with an easy-to-follow layout plan before leaving our UK factory.

Whether you choose a fixed fuelbed, or loose logs, our oak-finished fires deliver an equally authentic real-fire experience, looking stunning when powered on, and naturally pleasing when off.



ELECTRIFLAME® DLX

100% – Natural Authentic Oak



Natural oak is available for all DLX models. *Custom loose logs come complete with a simple to follow layout guide, fully supported with instructional demonstration videos.



Retaining character



Log charring detail

Patented technologies bring new dimensions to the electric fire market as fuel bed and flames merge together in a living fire effect that blurs the line between reality and illusion. Cutting-edge technology replicates the natural flicker, color, and movement of real flames. This creates an authentic fire experience, the effects are astonishing, and are at the forefront of our premium electric fires.

WOODLAND CERAMIC LOGS



Blurring the lines between reality and illusion with naturally detailed woodland ceramic logs. *Ceramic logs come complete with a simple to follow layout guide, fully supported with instructional demonstration videos.



Bark chippings

Supplied with all DLX products

PATENTED TECHNOLOGIES

Multi Flame Projection Technology®

Living Ember Bed Technology®

DLX

DEFINED BY EXCELLENCE

DLX 2000 Natural Oak

Electrifiame DLX Built-In 3 Sided Glass Smart Fire

Features

- Multi Flame Projection Technology®
- Living Ember Bed Technology®
- Natural Oak Logs
- Bark chippings
- 16 pre-set colours/100+ custom/Animation mode
- LED brightness control
- Thermostatic remote & manual control operation
- CELSI App controllable. iOS & Android
- Amazon Alexa and Google Assistant compatible
- Side blanking for 2 & 1 sided installations



Celsi Smart Fires have 16 pre-set ambient colour modes, and over 100+ multi colour combinations to customise the light ambience on flames, logs, and ember bed. To simplify your choice relax and enjoy a slow cycle through the colour spectrum in our fully immersive Animation mode.



CELSI SMART APP

Feature-rich and simple to operate. Control your fire from your smart phone or tablet with full handset functionality.



3-sided glass installation. Natural Oak Logs.

Specification

Fire Dimensions: mm	H 393 x W 2002 x D 340
Heat Output	1.0kW – 2.0kW
Model Number	Custom Oak Logs EDXB20RE Resin Bonded Oak Logs EDXR20RE



Video



DLX 1800 Natural Oak

Electriflame DLX Built-In 3 Sided Glass Smart Fire

Features

- Multi Flame Projection Technology[®]
- Living Ember Bed Technology[®]
- Natural Oak Logs
- Bark chippings
- 16 pre-set colours/100+ custom/Animation mode
- LED brightness control
- Thermostatic remote & manual control operation
- CELSI App controllable. iOS & Android
- Amazon Alexa and Google Assistant compatible
- Side blanking for 2 & 1 sided installations



Celsi Smart Fires have 16 pre-set ambient colour modes, and over 100+ multi colour combinations to customise the light ambience on flames, logs, and ember bed. To simplify your choice relax and enjoy a slow cycle through the colour spectrum in our fully immersive Animation mode.



2-sided glass installation. Natural Oak Logs.



Video

Specification

Fire Dimensions: mm	H 393 x W 1802 x D 340
Heat Output	1.0kW – 2.0kW
Model Number	Custom Oak Logs EDXB18RE Resin Bonded Oak Logs EDXR18RE



CELSI SMART APP

Feature-rich and simple to operate. Control your fire from your smart phone or tablet with full handset functionality.



2-sided glass installation. Natural Oak Logs.



Video

Specification

Fire Dimensions: mm	H 393 x W 1602 x D 340
Heat Output	1.0kW – 2.0kW
Model Number	Custom Oak Logs EDXB16RE Resin Bonded Oak Logs EDXR16RE



CELSI SMART APP

Feature-rich and simple to operate. Control your fire from your smart phone or tablet with full handset functionality.

DLX 1600 Natural Oak

Electriflame DLX Built-In 3 Sided Glass Smart Fire

Features

- Multi Flame Projection Technology[®]
- Living Ember Bed Technology[®]
- Natural Oak Logs
- Bark chippings
- 16 pre-set colours/100+ custom/Animation mode
- LED brightness control
- Thermostatic remote & manual control operation
- CELSI App controllable. iOS & Android
- Amazon Alexa and Google Assistant compatible
- Side blanking for 2 & 1 sided installations



Celsi Smart Fires have 16 pre-set ambient colour modes, and over 100+ multi colour combinations to customise the light ambience on flames, logs, and ember bed. To simplify your choice relax and enjoy a slow cycle through the colour spectrum in our fully immersive Animation mode.





3-sided glass installation. Natural Oak Logs.



Video

Specification

Fire Dimensions: mm	H 393 x W 1252 x D 340
Heat Output	1.0kW – 2.0kW
Model Number	Custom Oak Logs EDXB12RE Resin Bonded Oak Logs EDXR12RE



CELSI SMART APP

Feature-rich and simple to operate. Control your fire from your smart phone or tablet with full handset functionality.

DLX 1250 Natural Oak

Electriflame DLX Built-In 3 Sided Glass Smart Fire

Features

- Multi Flame Projection Technology[®]
- Living Ember Bed Technology[®]
- Natural Oak Logs
- Bark chippings & charcoal embers
- 16 pre-set colours/100+ custom/Animation mode
- LED brightness control
- Thermostatic remote & manual control operation
- CELSI App controllable. iOS & Android
- Amazon Alexa and Google Assistant compatible
- Side blanking for 2 & 1 sided installations



Celsi Smart Fires have 16 pre-set ambient colour modes, and over 100+ multi colour combinations to customise the light ambience on flames, logs, and ember bed. To simplify your choice relax and enjoy a slow cycle through the colour spectrum in our fully immersive Animation mode.



DLX 2000 Woodland Ceramic

Electrifiame DLX Built-In 3 Sided Glass Smart Fire

Features

- Multi Flame Projection Technology®
- Living Ember Bed Technology®
- Woodland Ceramic logs
- Bark chippings & charcoal embers
- 16 pre-set colours/100+ custom/Animation mode
- LED brightness control
- Thermostatic remote & manual control operation
- CELSI App controllable. iOS & Android
- Amazon Alexa and Google Assistant compatible
- Side blanking for 2 & 1 sided installations



Celsi Smart Fires have 16 pre-set ambient colour modes, and over 100+ multi colour combinations to customise the light ambience on flames, logs, and ember bed. To simplify your choice relax and enjoy a slow cycle through the colour spectrum in our fully immersive Animation mode.



CELSI SMART APP

Feature-rich and simple to operate. Control your fire from your smart phone or tablet with full handset functionality.



3-sided glass installation. Woodland Ceramic Logs.

Specification

Fire Dimensions: mm	H 393 x W 2002 x D 340
Heat Output	1.0kW – 2.0kW
Model Number	Ceramic Logs EDXL20RE



Video



DLX 1800 Woodland Ceramic

Electriflame DLX Built-In 3 Sided Glass Smart Fire

Features

- Multi Flame Projection Technology[®]
- Living Ember Bed Technology[®]
- Woodland Ceramic logs
- Bark chippings & charcoal embers
- 16 pre-set colours/100+ custom/Animation mode
- LED brightness control
- Thermostatic remote & manual control operation
- CELSI App controllable. iOS & Android
- Amazon Alexa and Google Assistant compatible
- Side blanking for 2 & 1 sided installations



Celsi Smart Fires have 16 pre-set ambient colour modes, and over 100+ multi colour combinations to customise the light ambience on flames, logs, and ember bed. To simplify your choice relax and enjoy a slow cycle through the colour spectrum in our fully immersive Animation mode.



CELSI SMART APP

Feature-rich and simple to operate. Control your fire from your smart phone or tablet with full handset functionality.

Specification

Fire Dimensions: mm	H 393 x W 1802 x D 340
Heat Output	1.0kW – 2.0kW
Model Number	Ceramic Logs EDXL18RE

2-sided glass installation. Woodland Ceramic Logs.



Video



DLX 1600 Woodland Ceramic

Electriflame DLX Built-In 3 Sided Glass Smart Fire

Features

- Multi Flame Projection Technology[®]
- Living Ember Bed Technology[®]
- Woodland Ceramic logs
- Bark chippings & charcoal embers
- 16 pre-set colours/100+ custom/Animation mode
- LED brightness control
- Thermostatic remote & manual control operation
- CELSI App controllable. iOS & Android
- Amazon Alexa and Google Assistant compatible
- Side blanking for 2 & 1 sided installations



Celsi Smart Fires have 16 pre-set ambient colour modes, and over 100+ multi colour combinations to customise the light ambience on flames, logs, and ember bed. To simplify your choice relax and enjoy a slow cycle through the colour spectrum in our fully immersive Animation mode.



3-sided glass installation. Woodland Ceramic Logs.



Video

Specification

Fire Dimensions: mm	H 393 x W 1602 x D 340
Heat Output	1.0kW – 2.0kW
Model Number	Ceramic Logs EDXL16RE



CELSI SMART APP

Feature-rich and simple to operate. Control your fire from your smart phone or tablet with full handset functionality.



DLX 1250 Woodland Ceramic

Electriflame DLX Built-In 3 Sided Glass Smart Fire

Features

- Multi Flame Projection Technology[®]
- Living Ember Bed Technology[®]
- Woodland Ceramic logs
- Bark chippings & charcoal embers
- 16 pre-set colours/100+ custom/Animation mode
- LED brightness control
- Thermostatic remote & manual control operation
- CELSI App controllable. iOS & Android
- Amazon Alexa and Google Assistant compatible
- Side blanking for 2 & 1 sided installations



Celsi Smart Fires have 16 pre-set ambient colour modes, and over 100+ multi colour combinations to customise the light ambience on flames, logs, and ember bed. To simplify your choice relax and enjoy a slow cycle through the colour spectrum in our fully immersive Animation mode.



CELSI SMART APP

Feature-rich and simple to operate. Control your fire from your smart phone or tablet with full handset functionality.

3-sided glass installation. Woodland Ceramic Logs.



Video

Specification

Fire Dimensions: mm	H 393 x W 1252 x D 340
Heat Output	1.0kW – 2.0kW
Model Number	Ceramic Logs EDXL12RE

DLX 1250 Media Wall Suite

Pre-Built DLX Fire Media Wall Package

Our pre-built media wall suites are crafted in the UK using premium quality Egger boards in a choice of Cupria Slate, or Smooth White with Acoustic Oak panels. The media wall suite comes in three easy-to-assemble parts, making installation simple. Our design incorporates a log storage compartment, and a TV recessed compartment with a cut-out rear panel to flush-mount your TV.

The Suite package includes our 1250 DLX electric fire with natural Oak logs and bark chippings.

Features

- DLX 3-Sided Glass Smart Fire
- Multi Flame Projection Technology®
- Living Ember Bed Technology®
- Heat Output 1.0kW - 2.0kW
- Natural Oak Logs & Bark chippings
- 16 pre-set colours/100+ custom/Animation mode
- LED brightness control
- Thermostatic remote & manual control operation
- CELSI App controllable. iOS & Android
- Amazon Alexa and Google Assistant compatible



Video

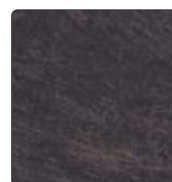

Cupria Slate



THERMO-STATIC



7 DAY TIMER



ENERGY SAVING



ISO FLAME



COLOUR SMART



REAL WOOD

Specification

Specification	DLX 1250 Media Wall
Suite Dimensions: mm	H 2200 x W 1570 x D 420
Heat Output	1.0kW – 2.0kW
Premium Board Paint Finish	Model Number
Cupria Slate	EDXB12RE-MWG
White & Acoustic Oak	EDXB12RE-MWW

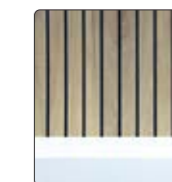

White & Acoustic Oak



Video



DLX 1250 Monroe Suite

Electriflame DLX 3 Sided Fire Suite

Crafted in the UK using premium quality Egger boards in Smooth White with Acoustic Oak panels. This suite comes fully assembled complete with our popular sized 1250 DLX Natural Oak log fire. Suite installation is as simple as placing down and plugging in.

Features

- DLX 3-Sided Glass Smart Fire
- Multi Flame Projection Technology®
- Living Ember Bed Technology®
- Natural Oak Logs
- Bark chippings
- 16 pre-set colours/100+ custom/Animation mode
- LED brightness control
- Thermostatic remote & manual control operation
- CELSI App controllable. iOS & Android
- Amazon Alexa and Google Assistant compatible



Video

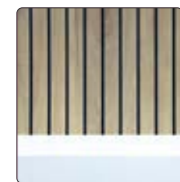

White & Acoustic Oak

Specification

Fire Dimensions: mm	H 393 x W 1602 x D 420
Heat Output	1.0kW – 2.0kW
Premium Board Paint Finish White & Acoustic Oak	Model Number EDX12SRE-MSW



CELSI SMART APP

Feature-rich and simple to operate. Control your fire from your smart phone or tablet with full handset functionality.



FIRE DIMENSIONS

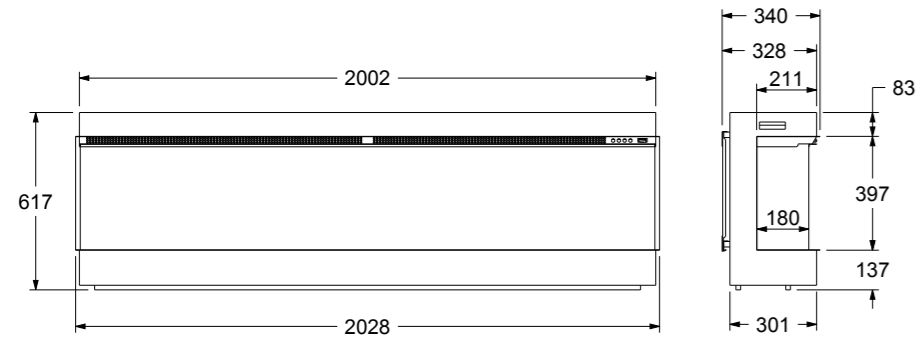

ELECTRIFLAME® DLX 2000

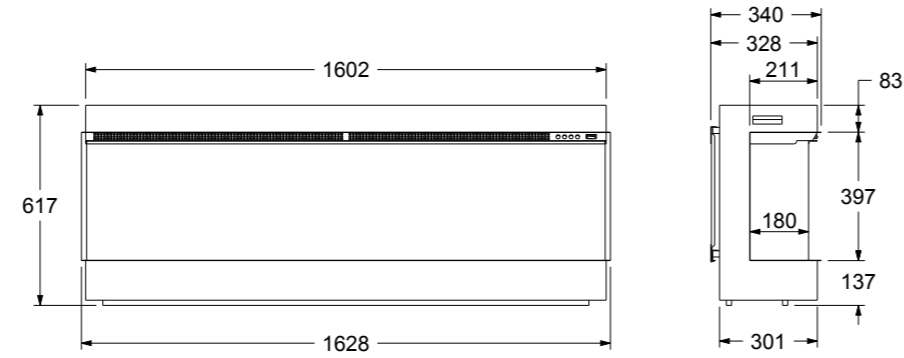

ELECTRIFLAME® DLX 1600

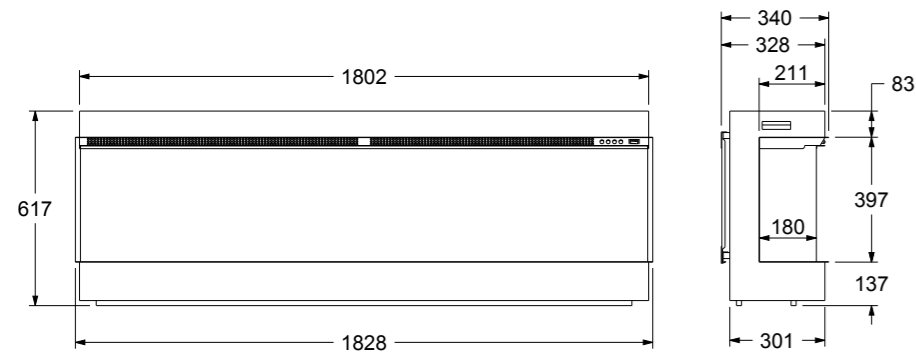

ELECTRIFLAME® DLX 1800

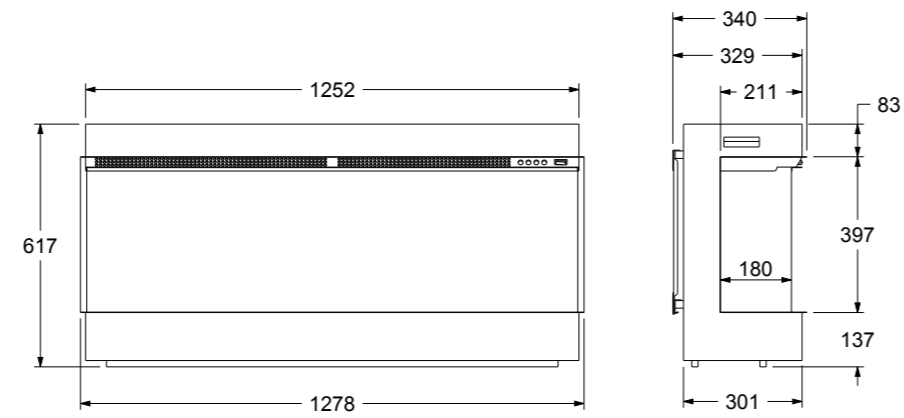

ELECTRIFLAME® DLX 1250

SUITE DIMENSIONS

Measurements in millimetres

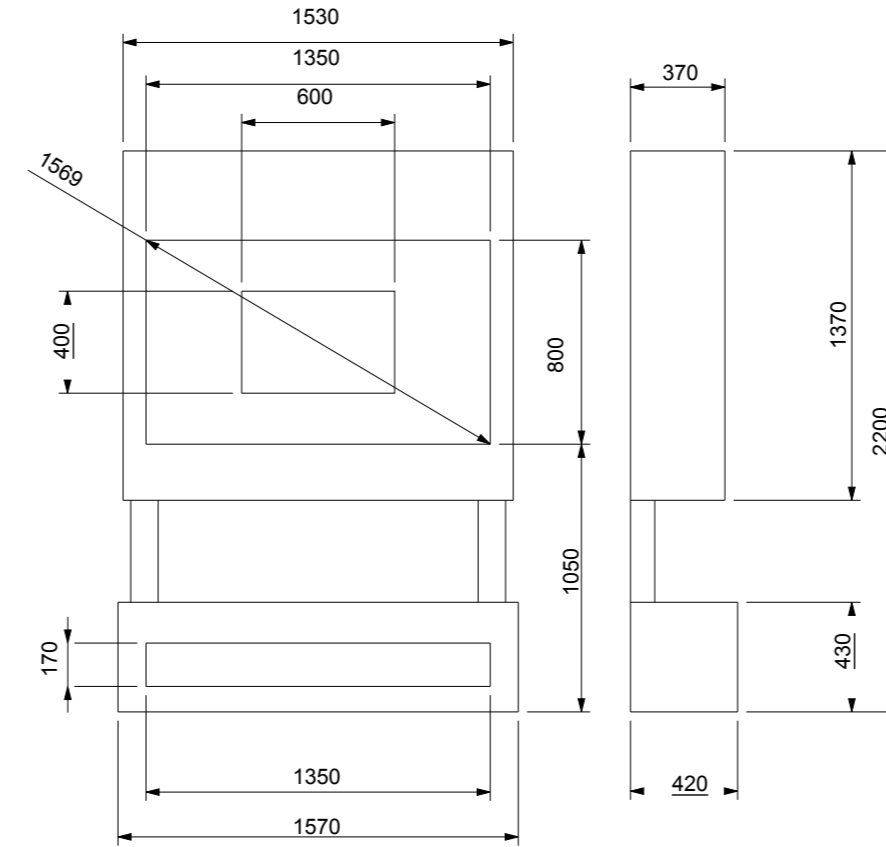

ELECTRIFLAME® DLX 1250 MEDIA WALL SUITE

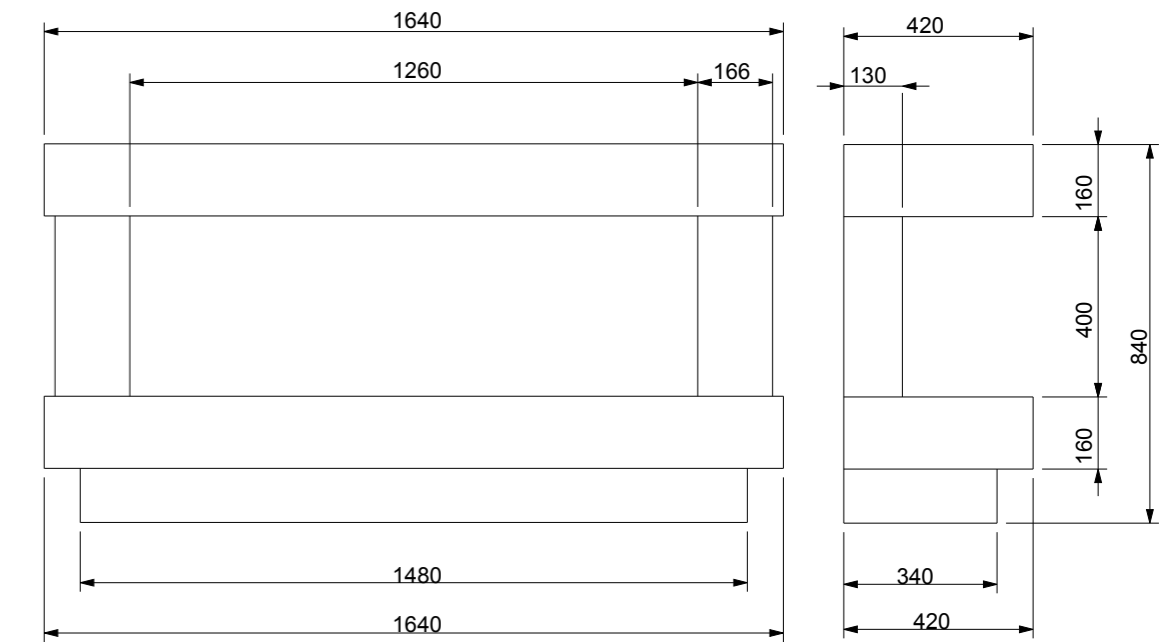

ELECTRIFLAME® DLX 1250 MONROE SUITE



www.celsielectricfires.co.uk

Go direct to the Celsi website on your smart phone or tablet device and use the app to scan the black and white QR codes shown on each page. Alternatively, go to www.celsielectricfires.co.uk to browse all Celsi electric fires.



BFM Europe Ltd, Gordon Banks Drive, Trentham Lakes, Stoke-on-Trent ST4 4TJ
Tel:01782 339000 Email: sales@bfm-europe.com

DISCLAIMER

Our policy is one of constant development and improvement. We therefore reserve the right to revise designs and specifications of our products without formal notice, patents pending. We always recommend our products to be viewed in an approved showroom before purchase. Whilst we have taken every care in the preparation of this brochure it is not intended to replace the installation manual which provides more detailed information.

Photography is for illustration purposes only and although every effort has been made to ensure accurate reproduction of typical installations and flame pictures they may vary according to fire model and installation methods.

We recommend that all our fires are used in conjunction with central heating and not as a primary source of heat. In the interests of personal safety a suitable fireguard is recommended when children, the elderly and the infirm are present.

We accept no liability for any loss or damage arising directly or indirectly from the use of this brochure. This brochure is copyright 2023 and must not be reproduced in whole or in any part without prior written permission.

